

# Intel® Core™ 2 Duo VME x86 Processor Blade with SCSI



## Product Datasheet - Preliminary

PDSi's **Intel-based VME x86 Processor Blade** (VM86-N2) is a robust, high-performance general purpose compute platform for use in VME systems. This VME board is the latest addition to PDSi's family of computing solutions built around Intel's Core 2 Duo processor. Featuring the server-grade Intel 5100 chipset, this double-wide blade supports up to 4GB of ECC memory. It offers a convenient, pin-compatible replacement for legacy 7751-based systems while offering upgraded technology, higher performance, more memory and an extended product lifecycle.

The two-board VM86-N2 blade includes a PMC site (or optional parallel port) on the lower board plus two additional PMC sites on the upper board. Dual gigabit Ethernet ports and dual USB 2.0 ports provide high-speed front communication links, and the VGA port gives access to high resolution graphics capability. Onboard storage options are available in the form of a 2.5 inch SATA hard drive and USB microDOC flash drive. Legacy application support includes front-mounted PS/2, dual serial and dual Ultra 160 SCSI channels, as well as rear floppy and SCSI interfaces. Rear I/O interfaces are pin-compatible with existing 7751-based RTMs.

PDSi gives telecom, aerospace, and military OEMs the ability to deploy and upgrade high-reliability VME solutions using this powerful compute blade based on the latest Intel technology. Extended availability from PDSi is assured as key components are supported by embedded roadmaps. PDSi can also provide customization, turnkey integration and support of VME systems, as well as extended warranty and repair services.



### Key Features



- Low power, high performance VME compute blade
  - Intel SL9400 Core 2 Duo 1.86 GHz
  - Intel 5100 MCH
- Up to 4GB Registered ECC DDR2 400 Memory
- Up to 3 PMC expansion sites
- VGA graphics up to 2048 x 1536 resolution
- 2 x 10/100/1000 Ethernet links
- Dual Ultra 160 SCSI channels
- Optional 2.5" SATA HDD up to 320 GB
- Optional USB Flash drive up to 8 GB
- 2 x USB 2.0
- 2 x RS 232 serial
- Rear 7751-compatible floppy and SCSI interfaces
- PS/2 keyboard/mouse port
- Extended availability assured

### Trusted Platforms for Critical Systems

PDSi's computing platforms are trusted by OEMs and ISVs across the globe to deliver mission critical solutions.

Target industries using PDSi products include:

- Military
- Aerospace
- Telecom
- Datacom / Networking
- Industrial
- Imaging

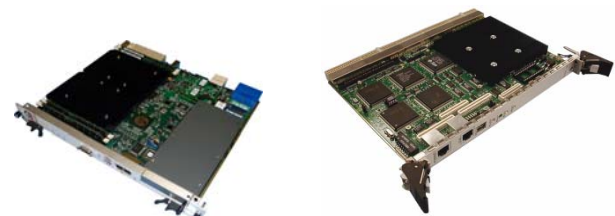



- Processors** Intel Core 2 Duo, SL9400
  - o 1.86 GHz, 1067 FSB
  - o Low power requirement
- Chipset** Intel 5100 MCH
  - o Server-grade
- Memory** 1 SORDIMM socket  
Up to 4GB DDR2 ECC 533/667 MHz  
Registered Memory
- NV Storage** Optional USB uDOC Flash drive, up to 8 GB
- PMC** 1 PMC mezzanine site with rear I/O pass-through (Board 1)
  - o PCI 32-bit/33 MHz
  - o Parallel Port option eliminates this site
 2 PMC mezzanine sites with rear I/O pass-through (Board 2)
  - o PCI 32-bit/33 MHz
- Parallel** Optional PATA parallel port (in place of lower PMC site)
- Graphics** ATI Radeon E2400 graphics controller, up to 2048 x 1536 resolution at 24 bit color depth.  
VGA front port.
- SATA HDD** 1 - 2.5 inch SATA HDD, up to 320 GB, optional, in place of PMC site 2
- SCSI** 2 – Ultra160 SCSI-3 channels, with SCSI-2 rear
- Compliance** VME-64X (ANSI/VITA 1.1-1997)  
RoHS Directive 2002/95/EC  
Designed for FCC/UL/CE



**Front Panel**

- Ethernet** 2 - Gigabit Ethernet RJ-45
- USB** 2 - USB 2.0 Type A
- SCSI** 2 channels, 68 pin connector
- VGA** 1 – HD-15 D-sub
- Serial** 2 – micro-DB9
- PS/2** Keyboard/mouse 6-pin DIN
- Parallel** (optional) 1 – DB-25F
- LEDs** Reset, Power, HD, Booting
- Sys Reset** Button

**Rear I/O (7751-compatible pinouts)**

- Floppy** Rear Floppy port
- IDE** IDE connection
- PMC** I/O pass-through from Pn4 connector(s)
- SCSI** Rear SCSI channel

**VME**

**Bridge** Tundra Tsi148 PCI-x to VME, 64 bit interface

**Power** Low power design

**Operating Systems** Linux, Windows (XP, Server2003)

**Form Factor/ Dimensions** 6U / 12T board  
160mm(D) x 233mm(H), double wide

**Temperature** Operation : -5 to 55 degC

**Humidity** 5% - 90% non-condensing

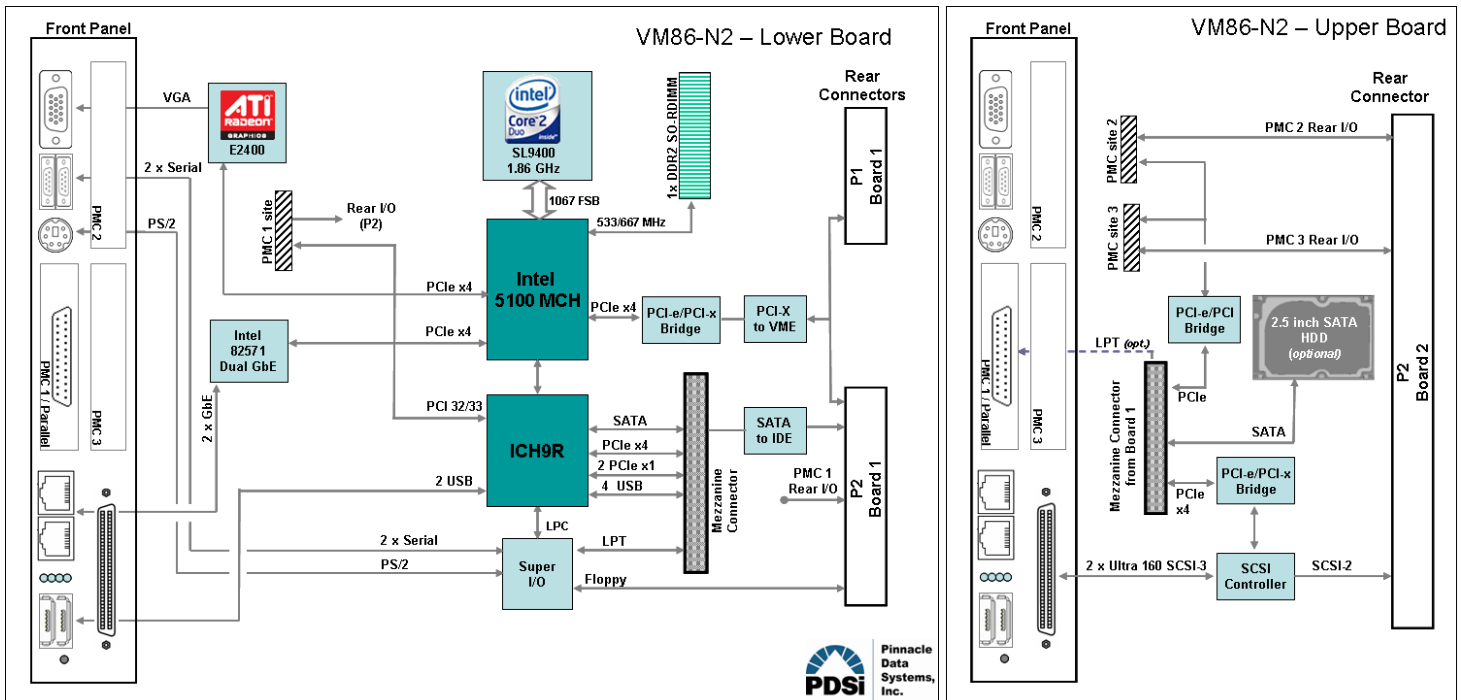



Ordering Guide	
To configure OPN:	VM86 - N2 - <input type="checkbox"/> - <input type="checkbox"/> - <input type="checkbox"/> - <input type="checkbox"/>
(1) Select Memory Size	<p><u>Parallel Port</u></p> <p><b>0</b> none</p> <p><b>P</b> Parallel Port in place of PMC on board 1</p> <p><u>USB Flash Storage</u></p> <p><b>0</b> none</p> <p><b>1</b> 1 GB</p> <p><b>2</b> 2 GB</p> <p><b>3</b> 4 GB</p> <p><b>4</b> 8 GB</p> <p><u>Onboard HDD</u></p> <p><b>0</b> none</p> <p><b>1</b> 160GB, HDD, 7.2K, Extended Availability ("EA")</p> <p><b>2</b> 250GB, HDD, 7.2K, Extended Availability ("EA")</p> <p><b>3</b> 320GB, HDD, 7.2K, Extended Availability ("EA")</p> <p><b>4</b> 80GB, SSD, Intel X25-M (Mainstream, MLC)</p> <p><b>5</b> 160GB, SSD, Intel X25-M (Mainstream, MLC)</p> <p><b>6</b> 32GB, SSD, Intel X25-E Model (Extreme, SLC)</p> <p><b>7</b> 64GB, SSD, Intel X25-E Model (Extreme, SLC)</p> <p><u>Memory</u></p> <p><b>A</b> 2GB DDR2 ECC Reg (667 MHz) SORDIMM</p> <p><b>B</b> 4GB DDR2 ECC Reg (667 MHz) SORDIMM</p>
(2) Select HDD	
(3) Optional Flash Storage	
(4) Select Parallel Port	